

A X4 Subharmonic Mixer for 24 GHz

Paul Drexler W2PED

- Background
- Mixer / Transverter Schemes
- Subharmonic Mixer review
- Lower Cost Mixer
- Practical Applications

W3CCX June 2002



Northeastern VHF Conference
w2ped April 2009



24 GHz Activity

Activity growth has been slow...

Motivation

Easier and more affordable hardware for the
24 GHz amateur band

Mixer Schemes

- Dual vs. Separate mixers for Rx / Tx
- Fundamental LO vs. Subharmonic

Fundamental Mixers

- LO = RF-IF (high frequency LO)
- Example: $24192 - 144 \text{ MHz} = 24048 \text{ MHz}$
- Straightforward mixer design
- Moderate conversion loss
- Low spurious energy

Fundamental Mixer CT1DMK Design

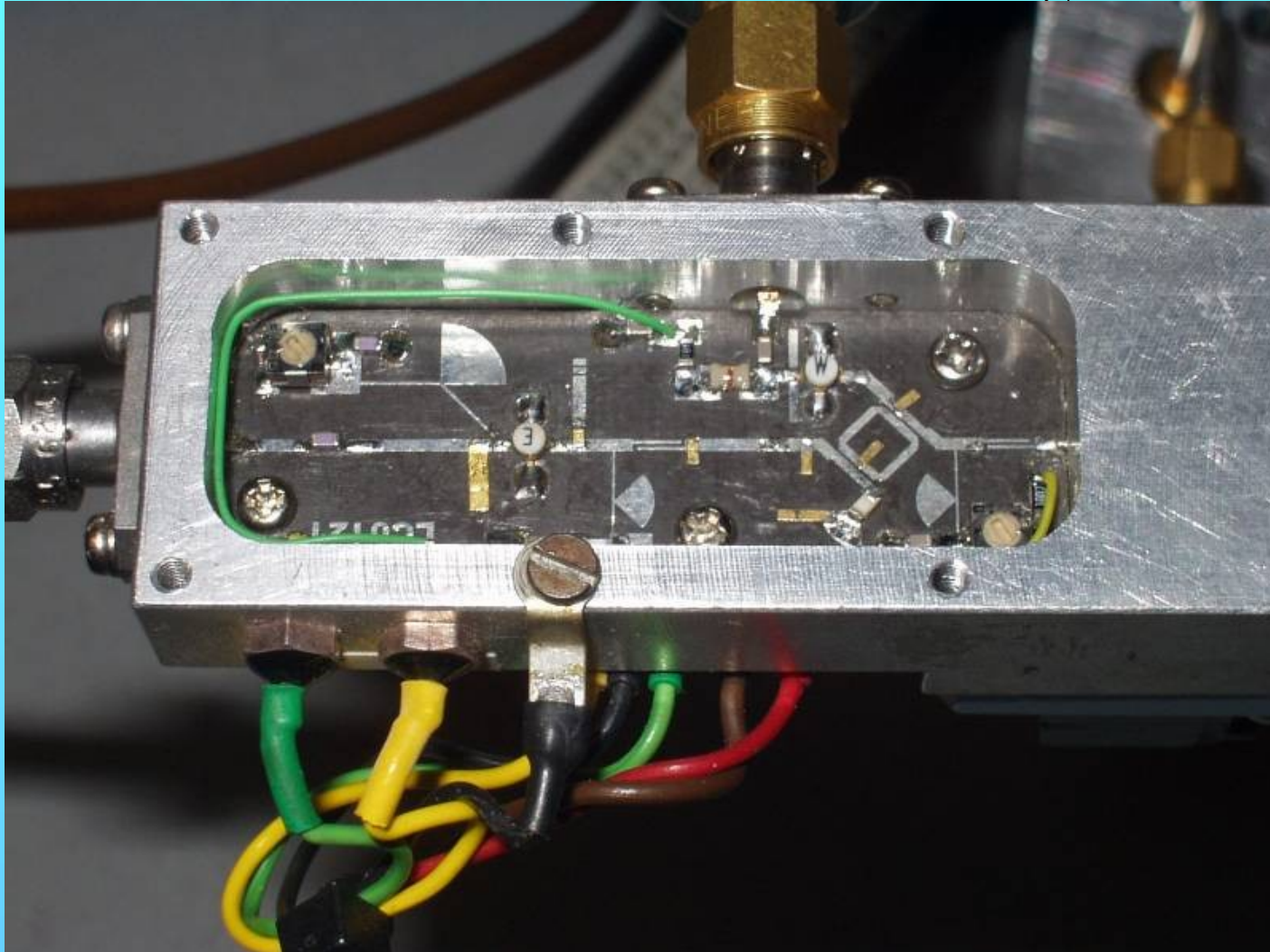

What's a Subharmonic Mixer?

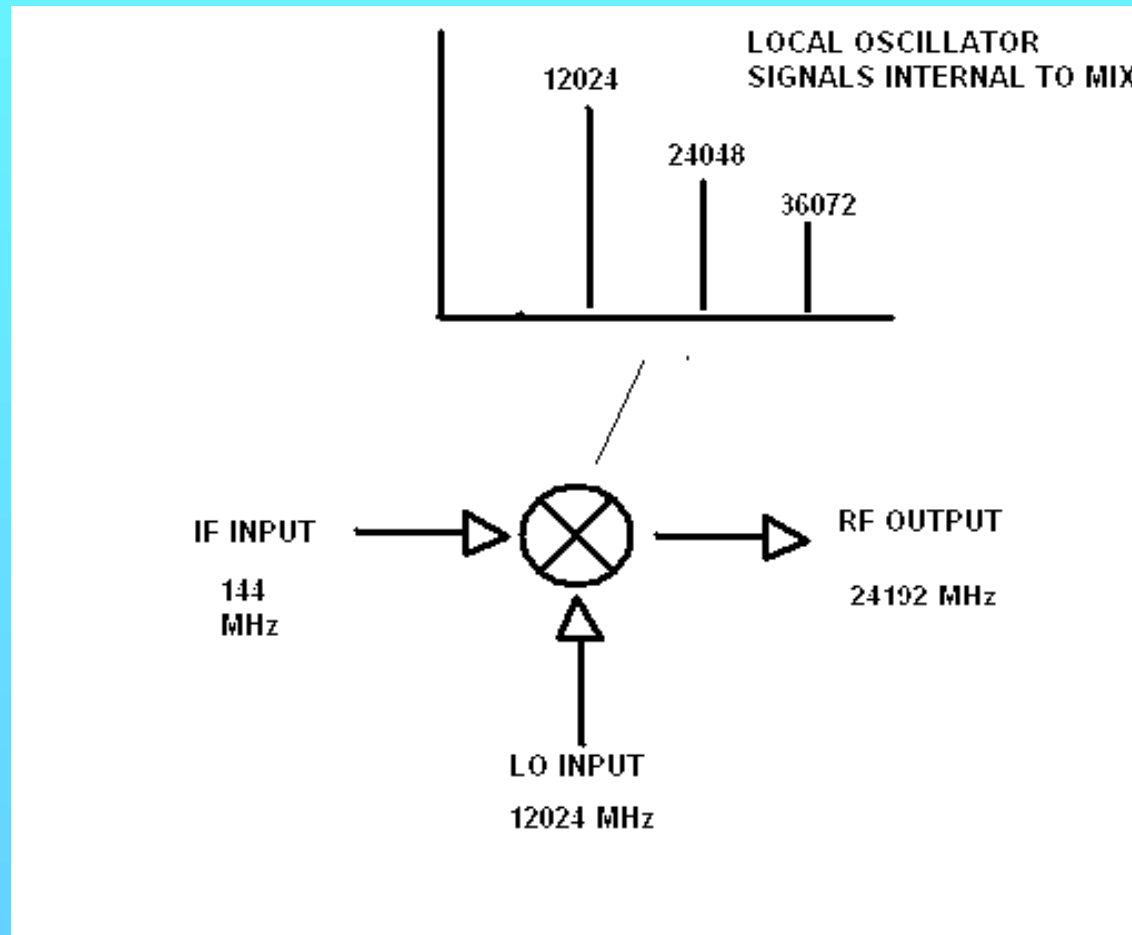

Subharmonic Mixers

- More elaborate mixer
- LO is at $\frac{1}{2}$, $\frac{1}{4}$, etc of standard LO
- LO ‘self multiplies’ internal to the mixer
- Lower frequency LO required
- Example: 12024 MHz for 24192-144 MHz

- Disadvantages: higher conversion loss, spurious

Some Commercial Harmonic Mixers (\$\$ \$)



Dual Mixer XVTR Block Diagram

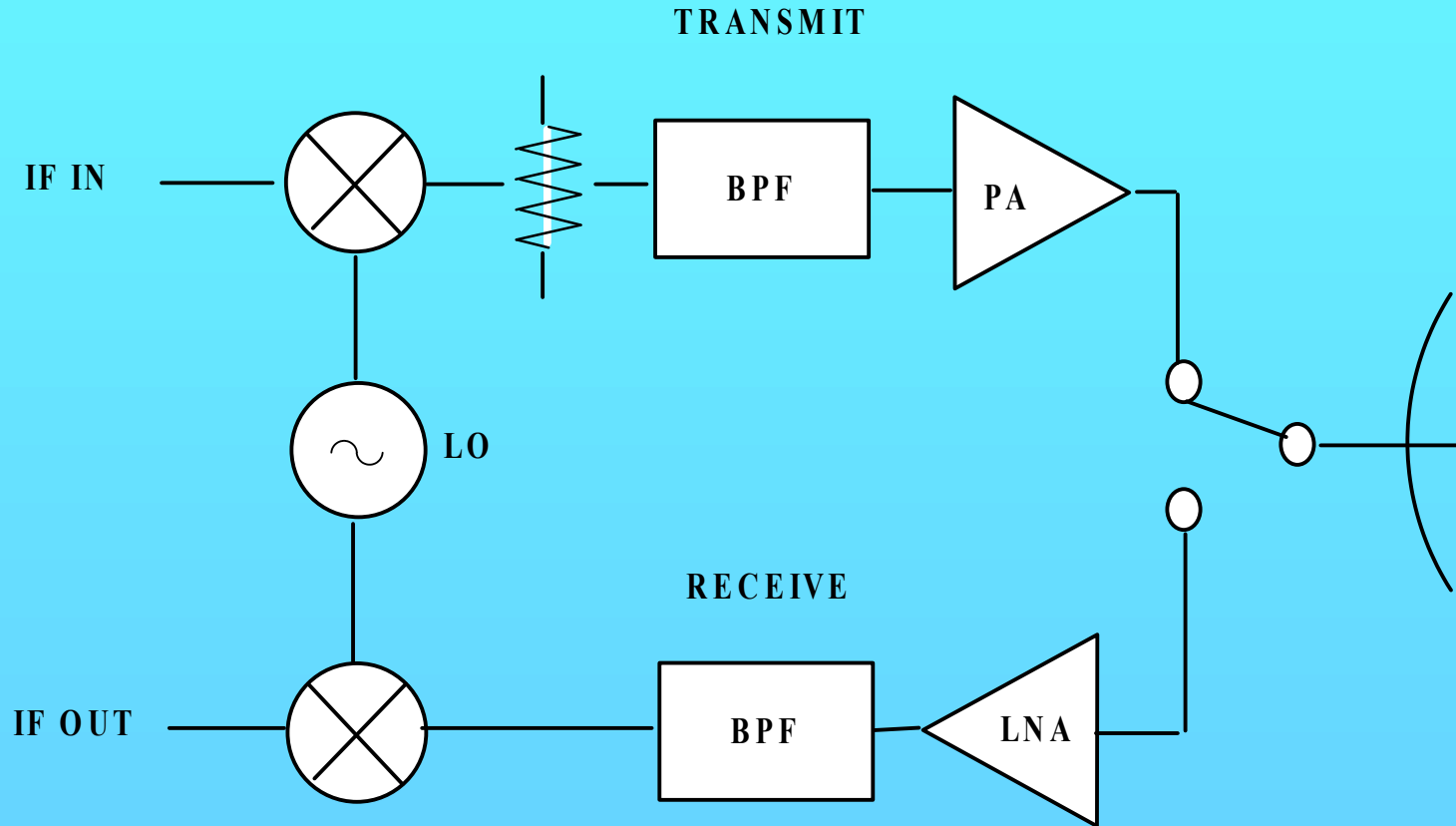

Single Mixer Approach

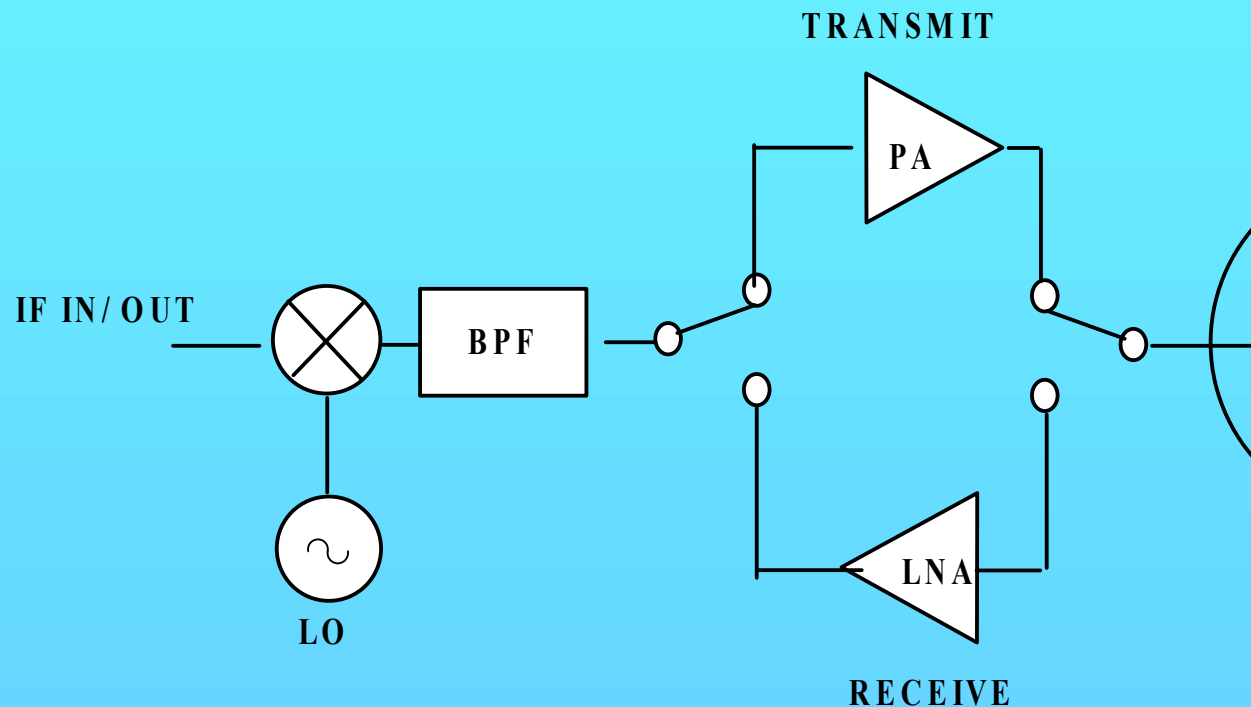

KM0T Block Diagram

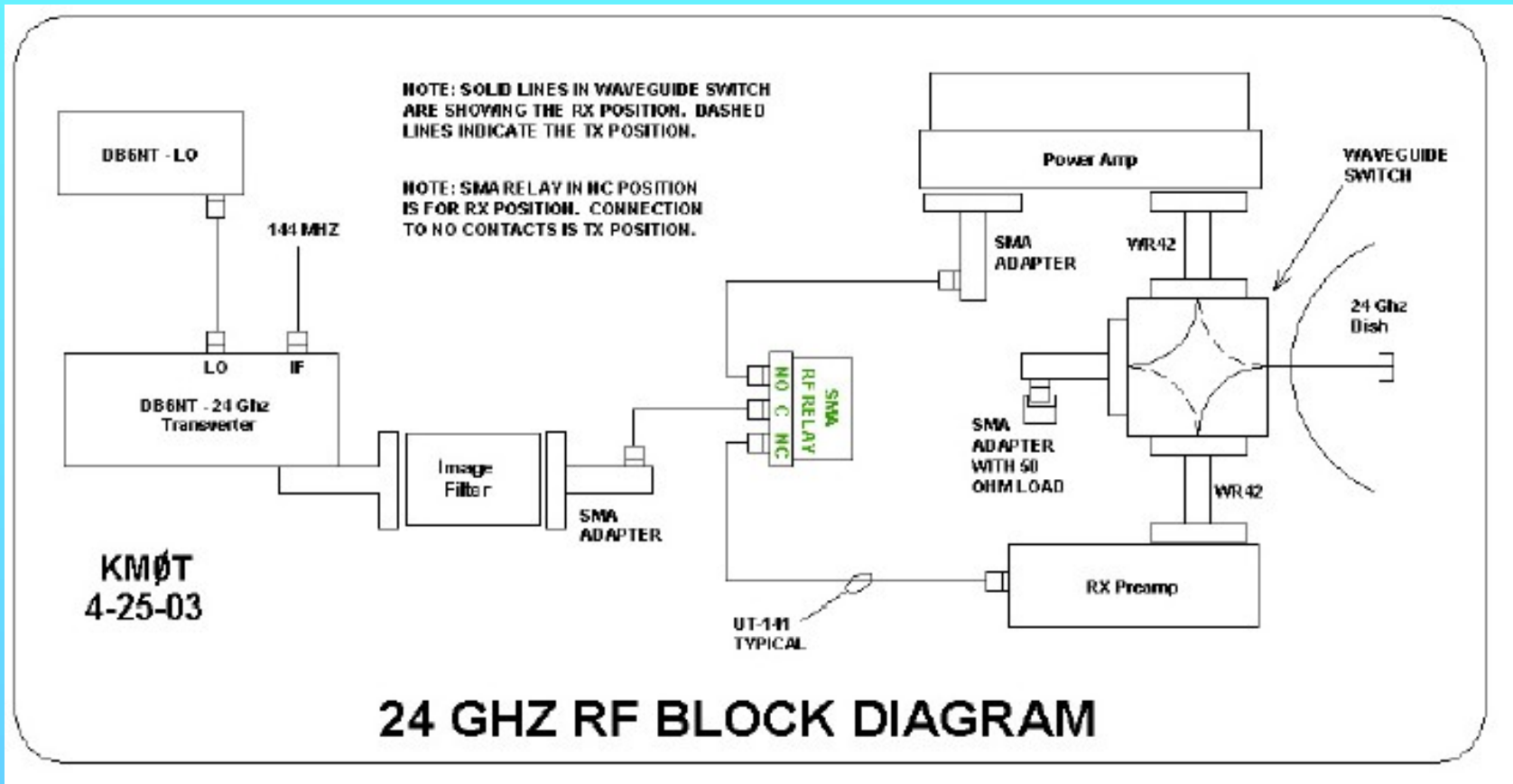

24 GHz Frequency Mixing Schemes

IF Freq	Fundamental LO	LO/2	W2PED LO/4
144 MHz	24048	12024	6012
432 MHz	23760	11880	5940

W2PED X4 Subharmonic Mixer for 24 GHz

- LO is at $\frac{1}{4}$ of **standard LO**, or ~ 6 GHz
- +10 dBm LO drive level
- Uses reflective idler circuits based on topology by Madjar
- WR42 Waveguide input/output

Anti-Parallel Diodes

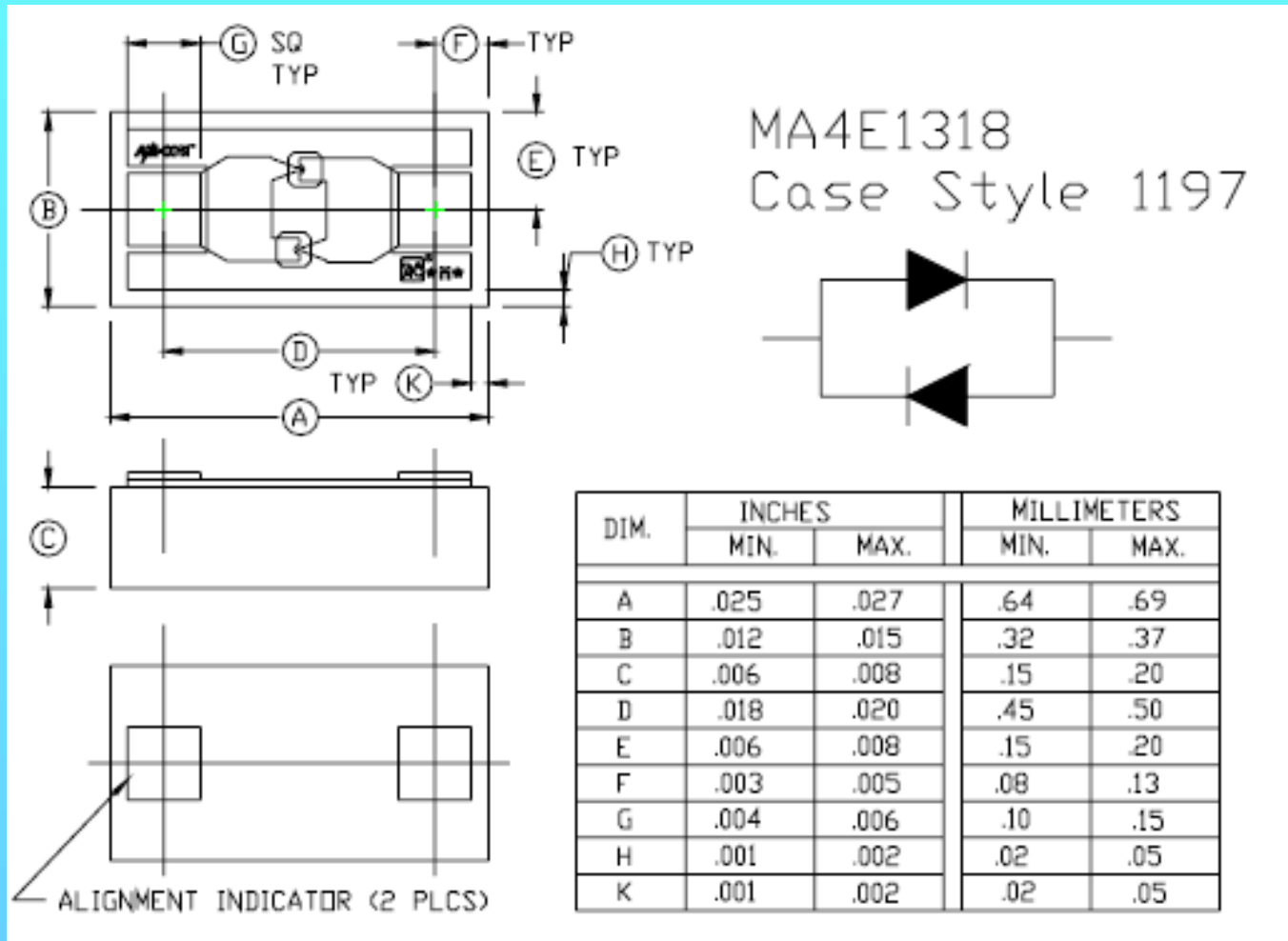

Mixer Topology

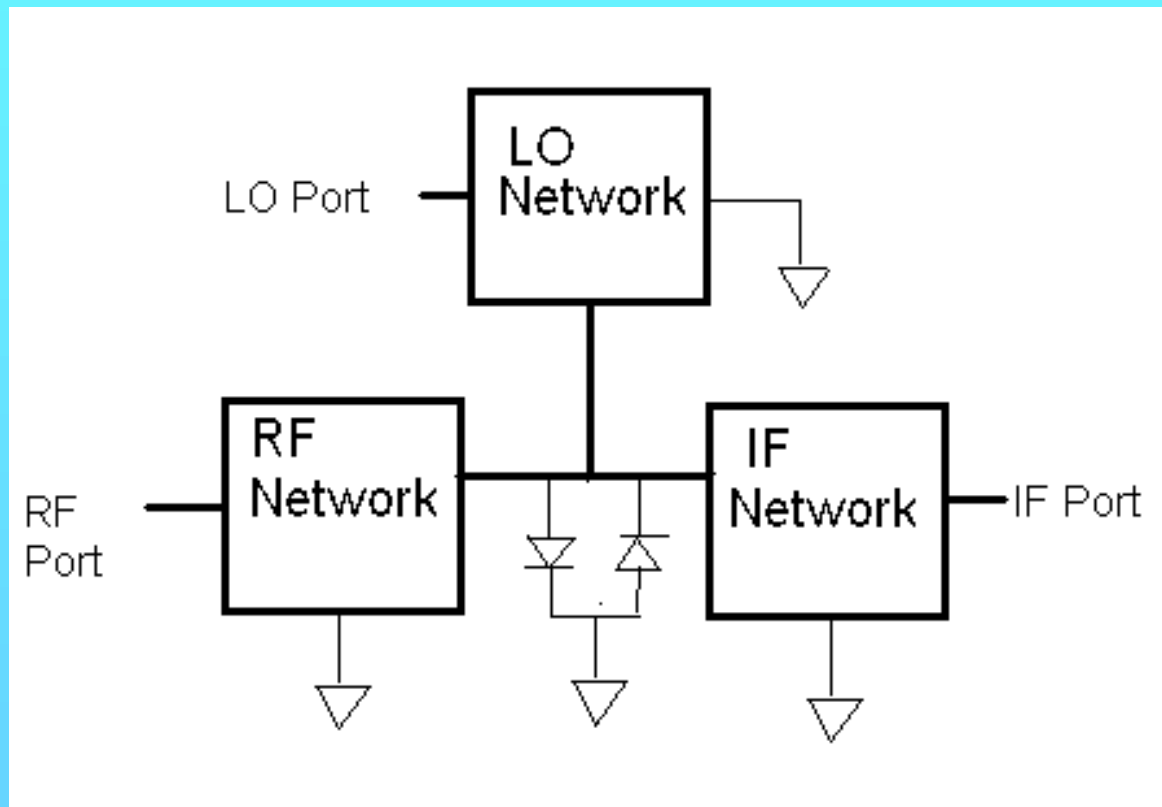

Optimize the RF, IF, and LO Networks...

Madjar's Conditions for Optimum CL

LO Network

At the LO freq: $s_{11}=s_{22}=0$ and $s_{21}=s_{12}=1$

At all other freqs: $s_{11}=s_{22}=1$ and $s_{21}=s_{12}=0$

(Note: magnitude only)

IF Network

At the IF freq: $s_{11}=s_{22}=0$ and $s_{21}=s_{12}=1$

At all other freqs: $s_{11}=s_{22}=1$ and $s_{21}=s_{12}=0$

Magnitude...

RF Network

At the RF freq: $s_{11}=s_{22}=0$ and $s_{21}=s_{12}=1$

At all other freqs: $s_{11}=s_{22}=1$ and $s_{21}=s_{12}=0$

and s_{11} is a variable angle

Magnitude and Phase!

- Reactive loading condition -

Design Focus / Goals

1. Conversion Loss
2. Minimize LO feed-through
3. Bandwidth
4. Return Loss

Design Flow

1. Preliminary network designs
2. Optimize each network
3. Connect
4. Tune for best CL / LO suppression
5. Reanalyze circuits using an EM simulator
6. Go back to #2 and do it again!

RF BPF

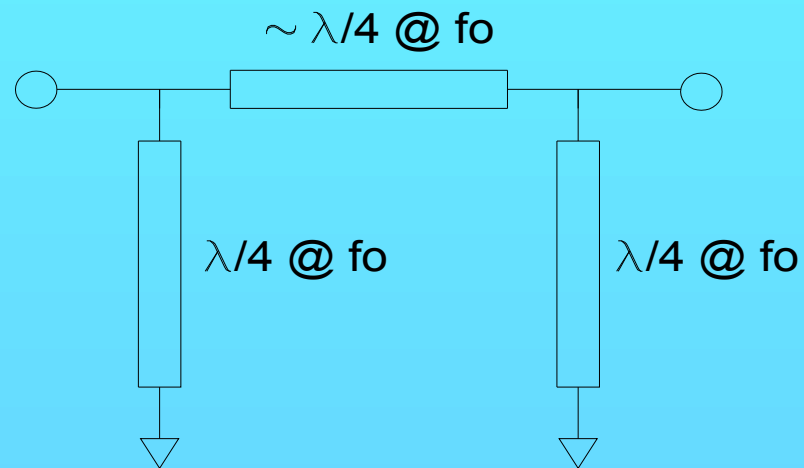

Traps Added

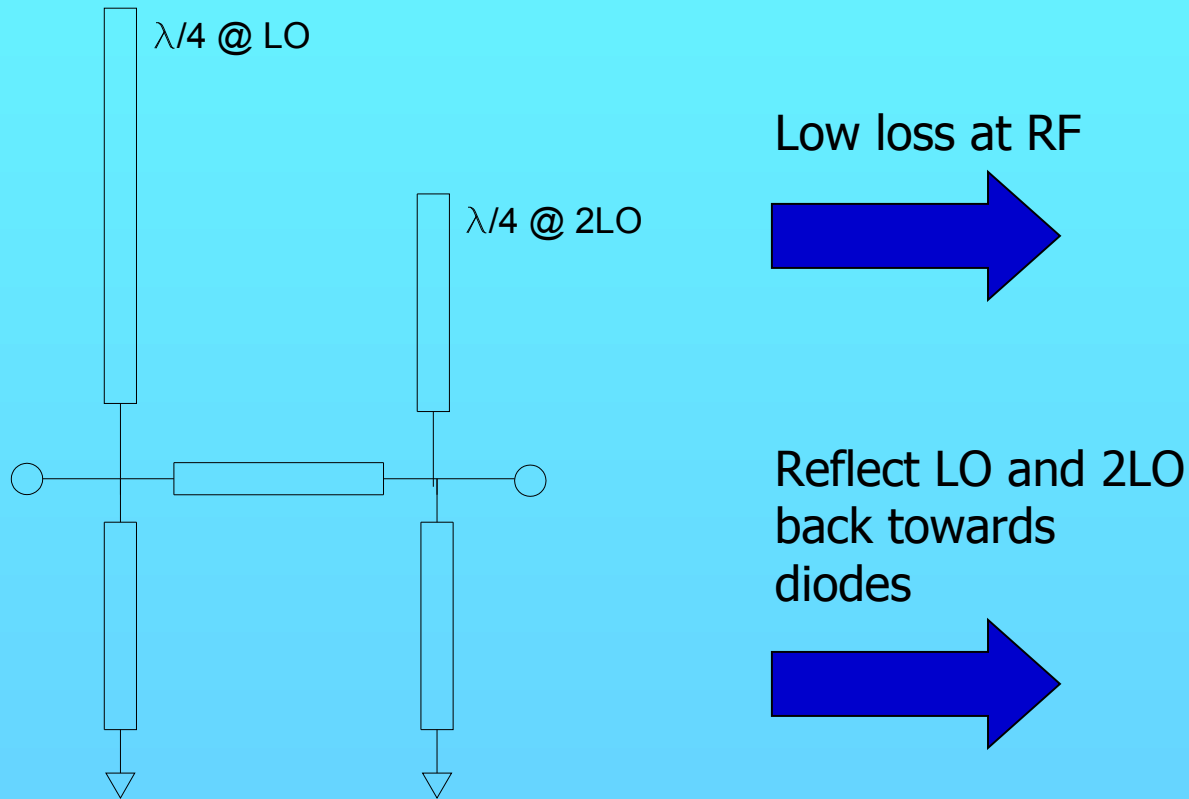

Predicted BPF Response

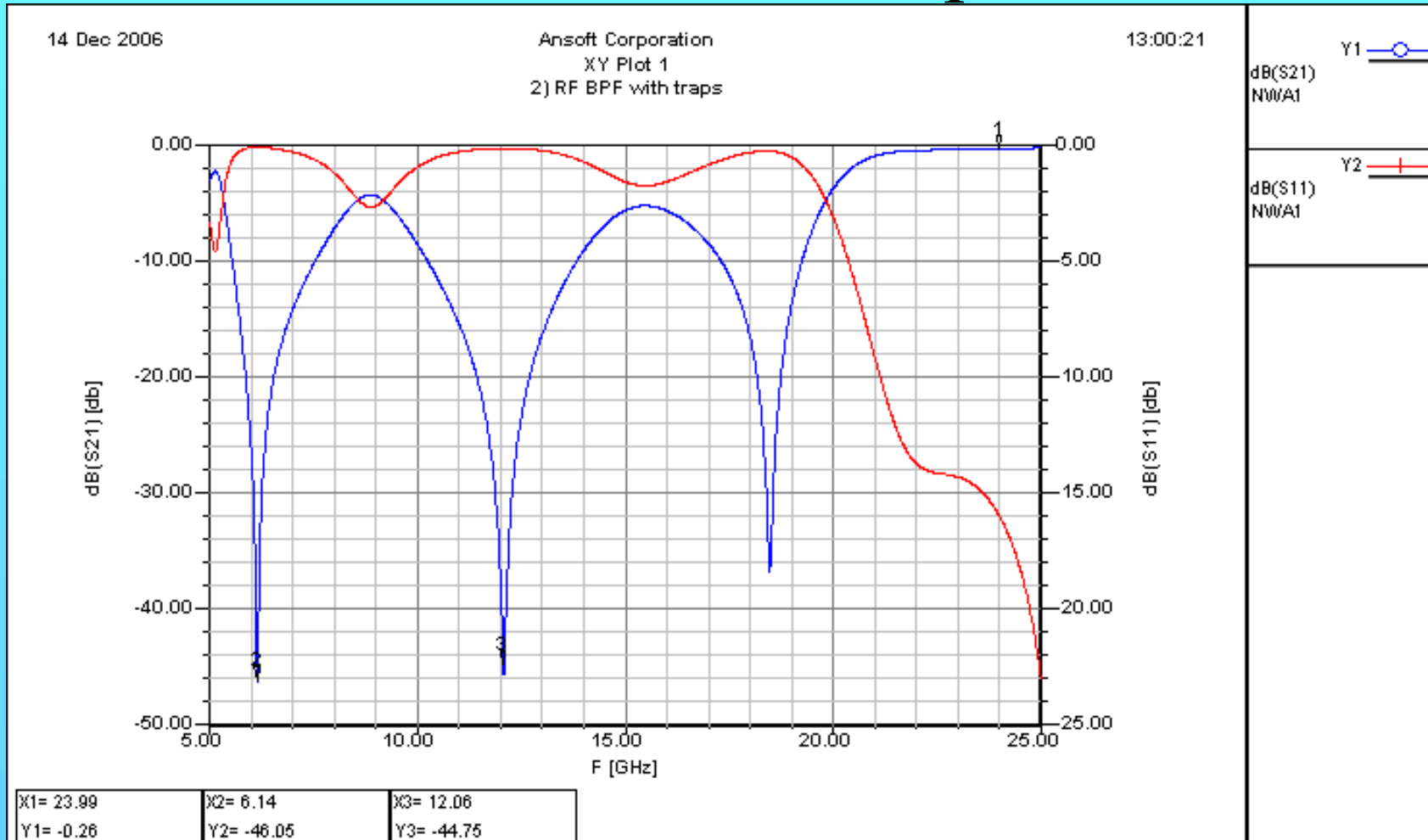

6 GHz LO Filter Section

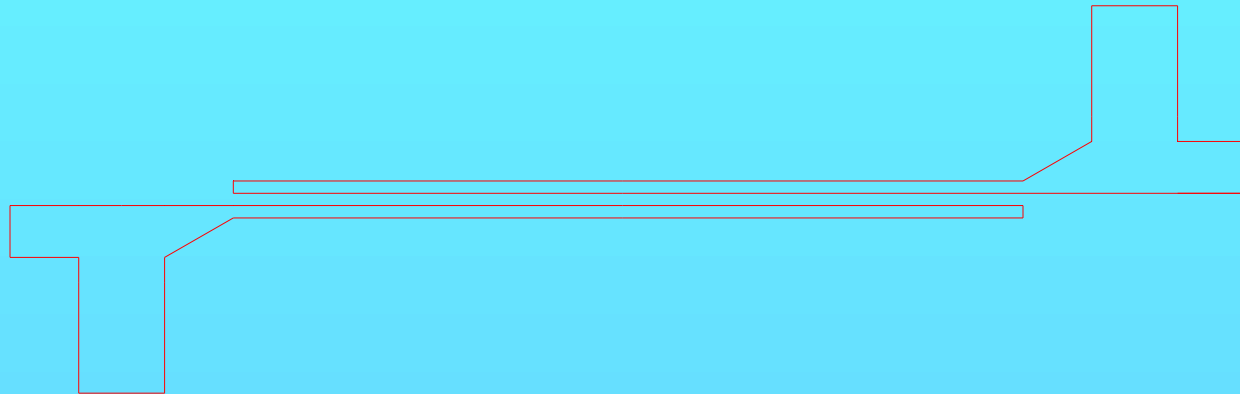

- Quarter wave, edge-coupled filter
- 4 mil lines and spaces

Components for 24 & 47GHz

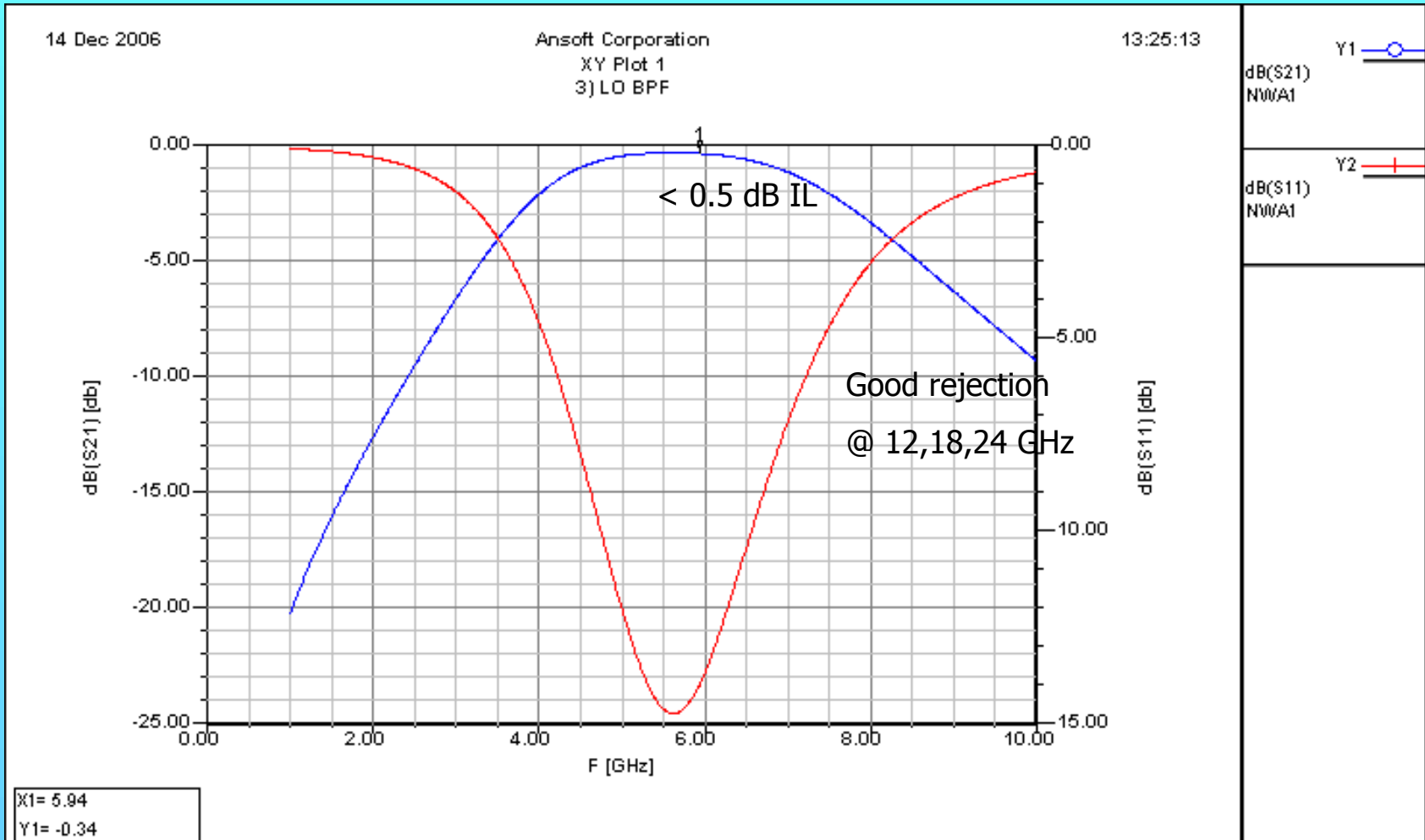

IF Section Layout

Reflect RF, LO and
2xLO energy back
towards diodes

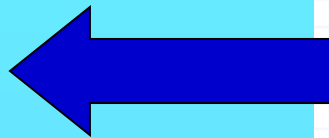

From Diodes

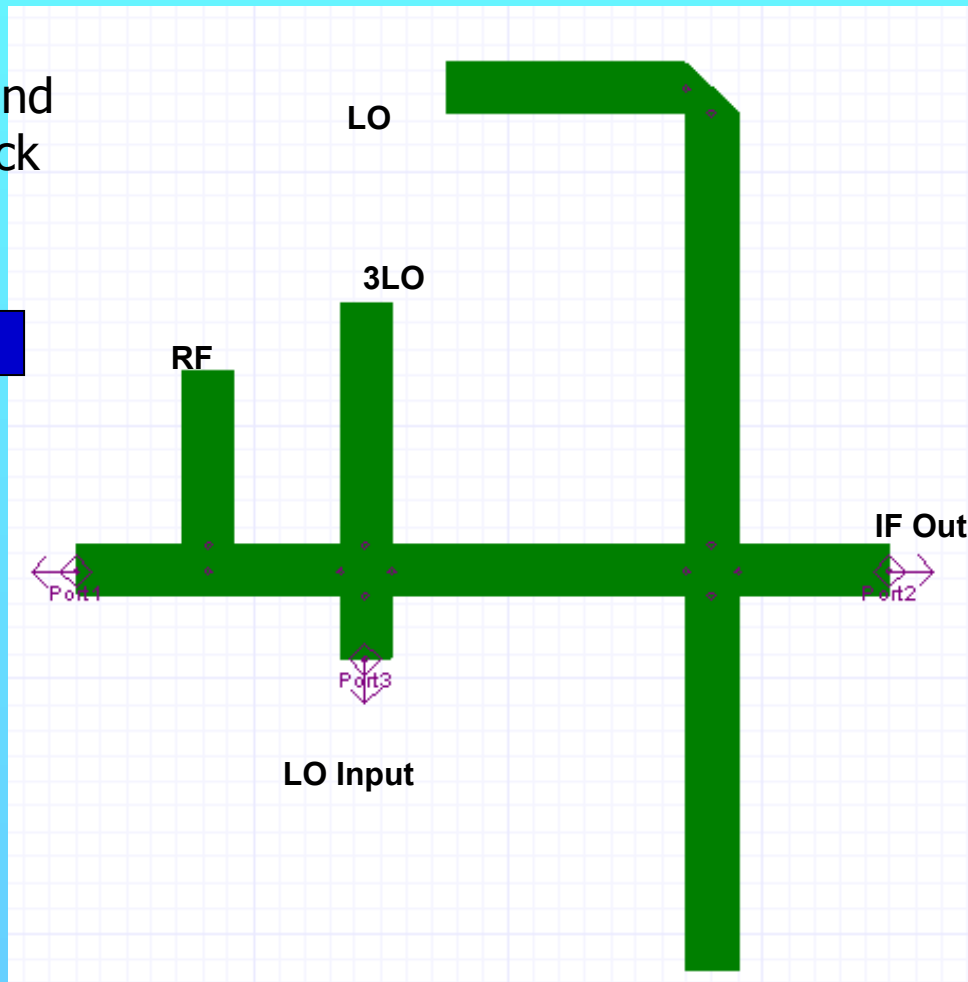

Low loss at
desired IF

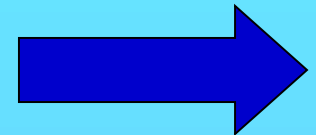

Congratulations...

- The design is almost finished....

Go Back and Do It Again!

10 Feb 2007

Ansoft Corporation

16:16:34

Spectral

8) Almost Final

LO=5940 MHz @ +11 dBm, RF=24 GHz @ -20 dBm

Y1= dBm(PO3) [dB]
HB2ToneMixer

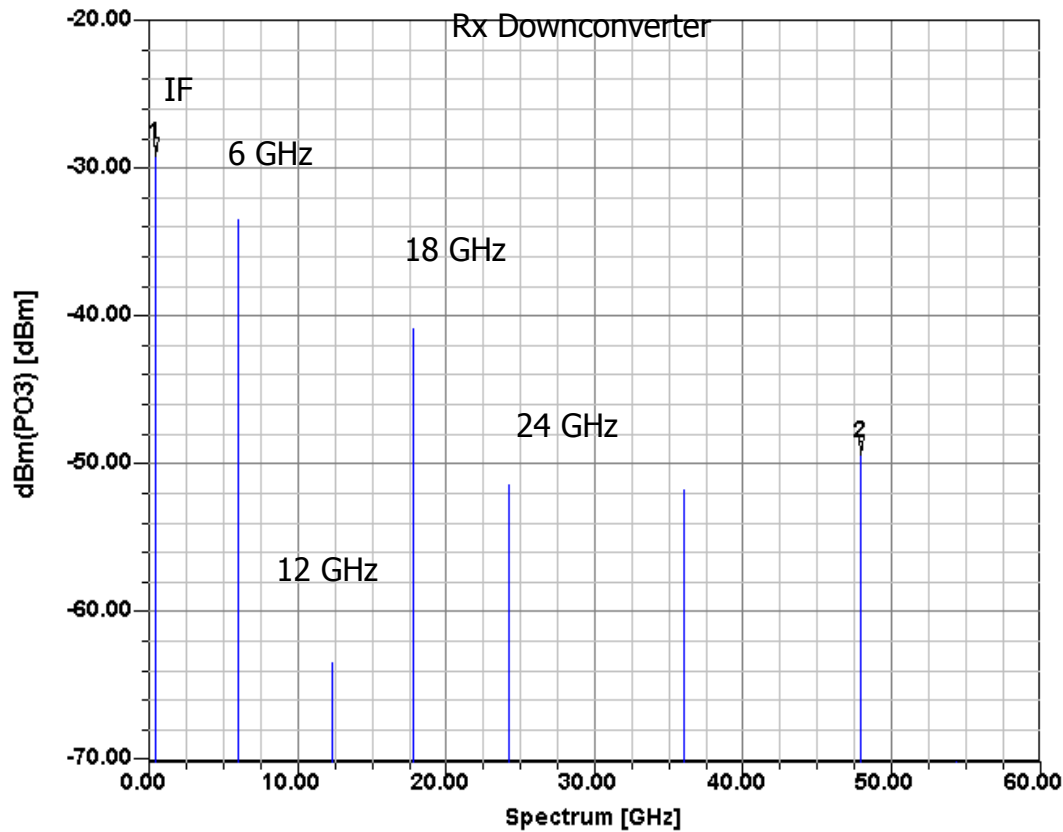

X1= 0.43	X2= 47.95
Y1= -29.08	Y2= -49.25

Model Prediction

8 dB Conversion Loss

WG to Microstrip

Microstrip Probe - HFSSDesign1 - 3D Modeler

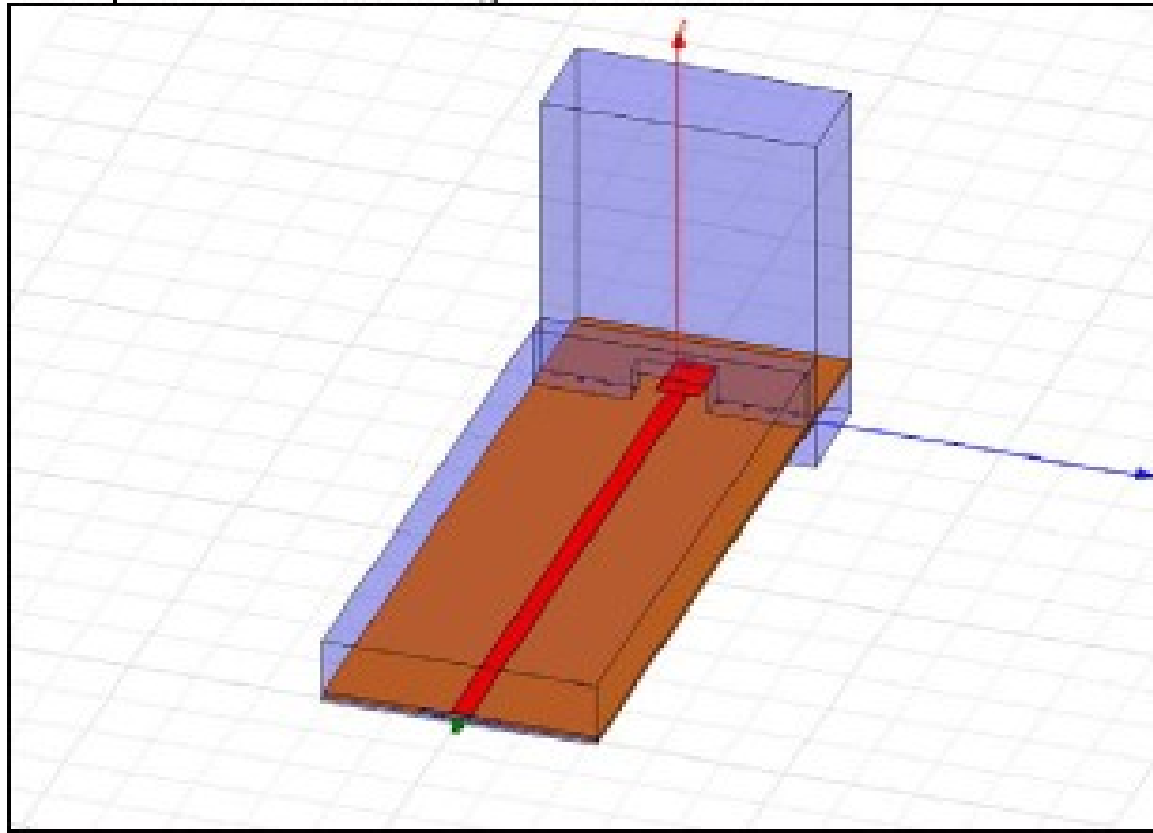

Mixer Assembly

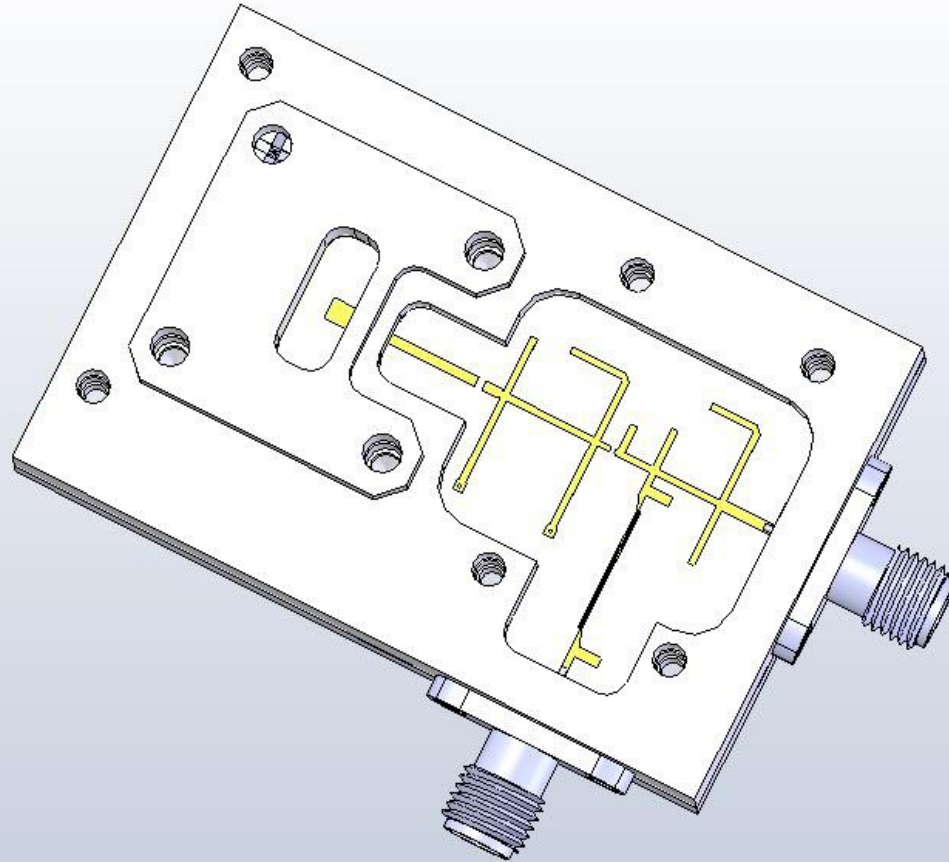

Top Level Mixer Assembly

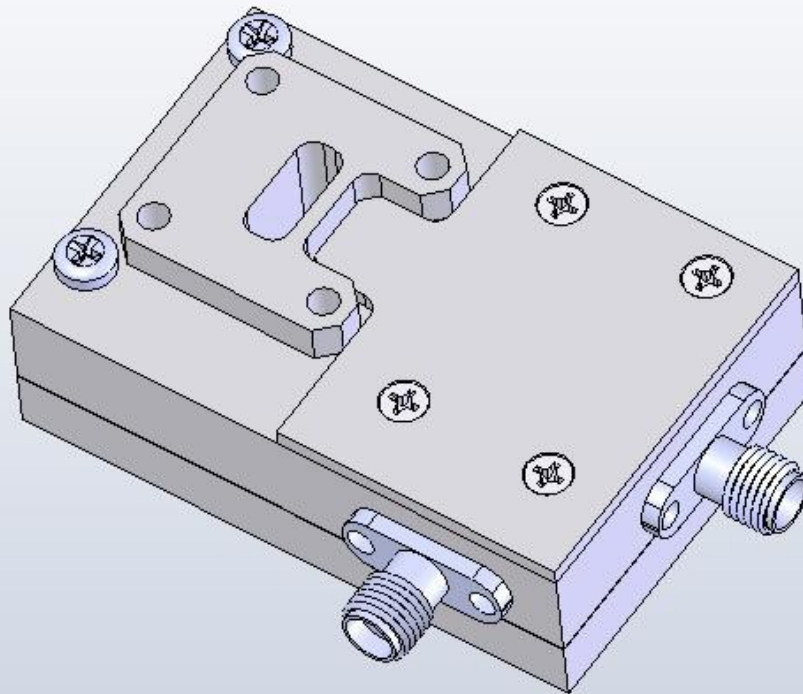

Artwork

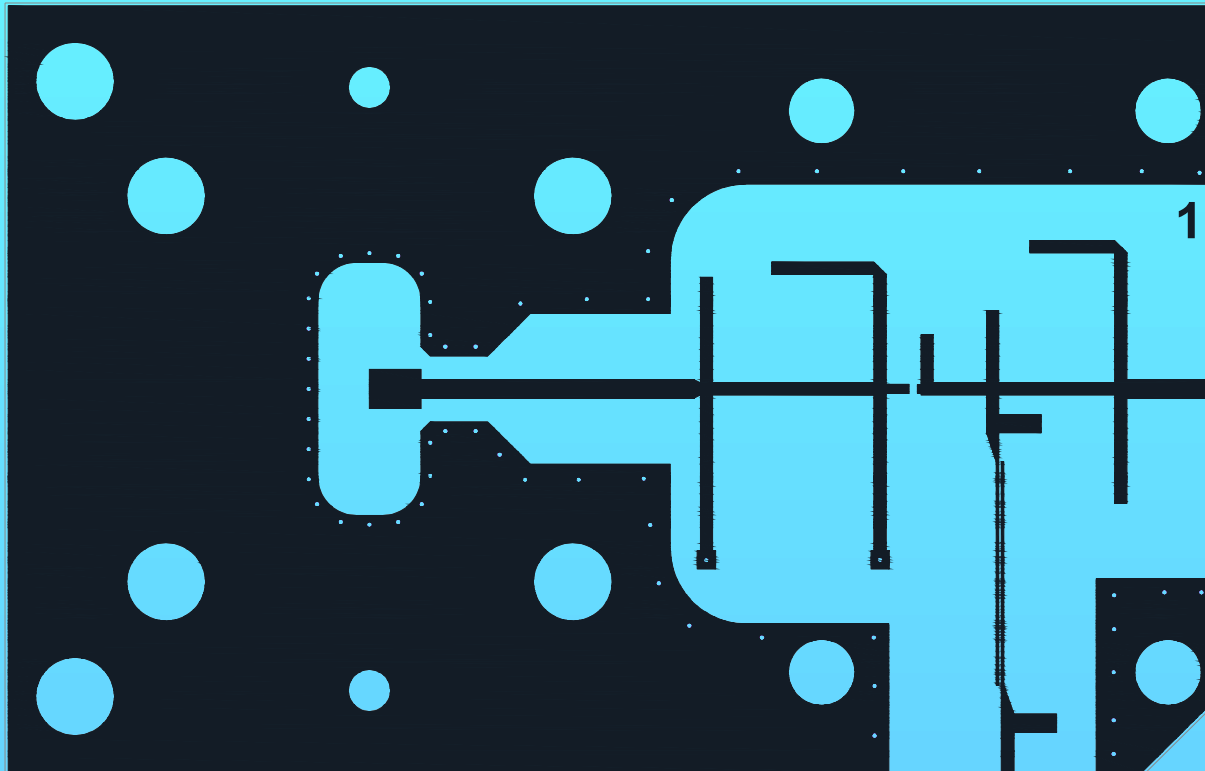

First Iteration X4 Subharmonic Mixer for 24 GHz



Downconverter Results

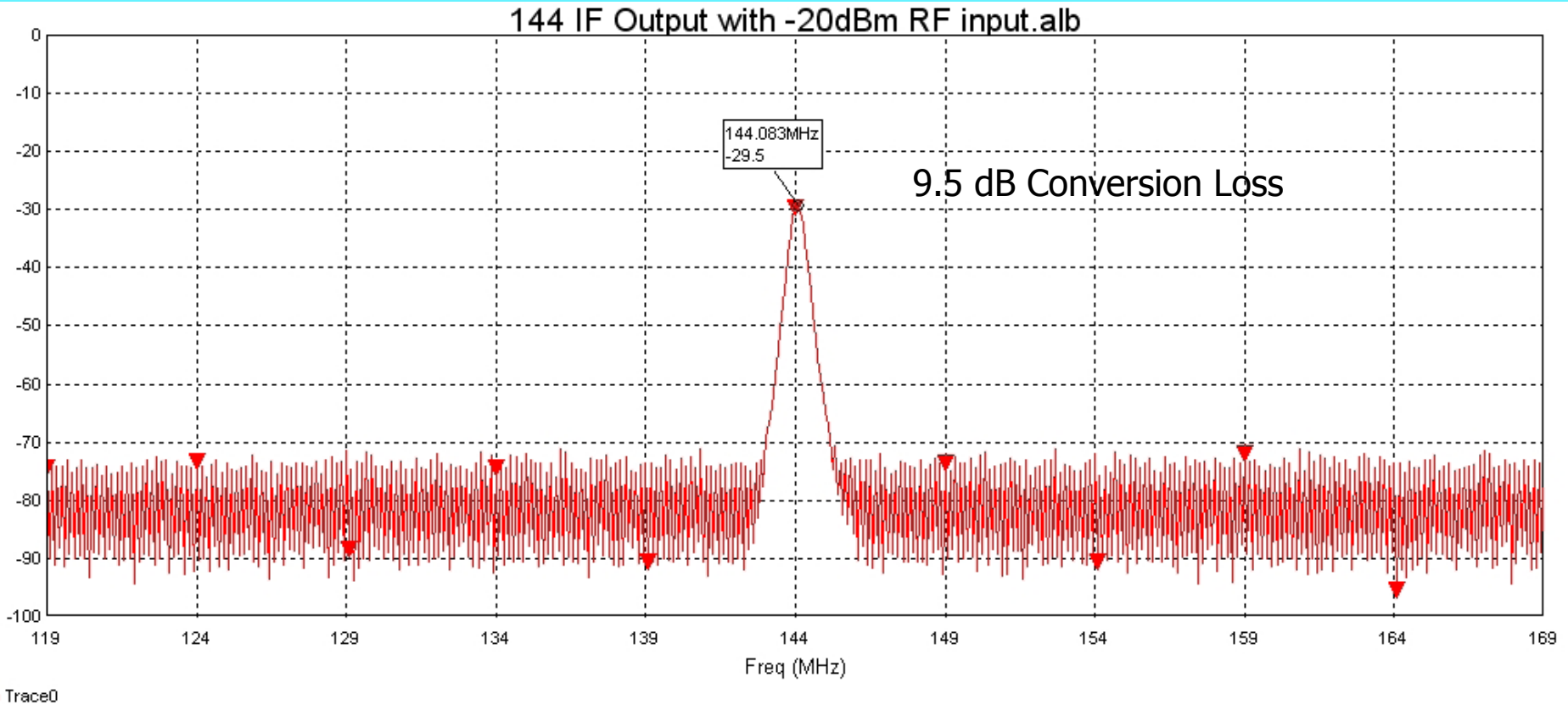

Upconverter Results

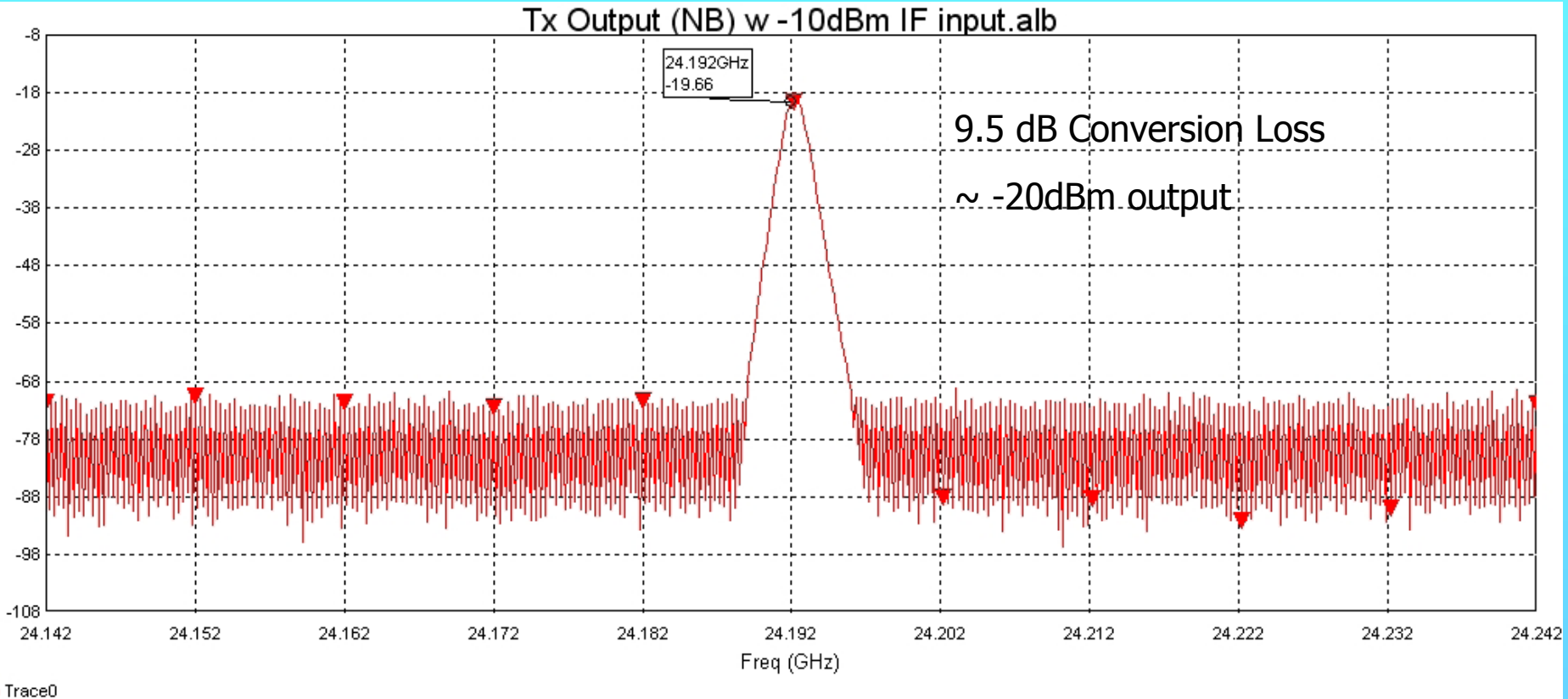

Broadband Transmit

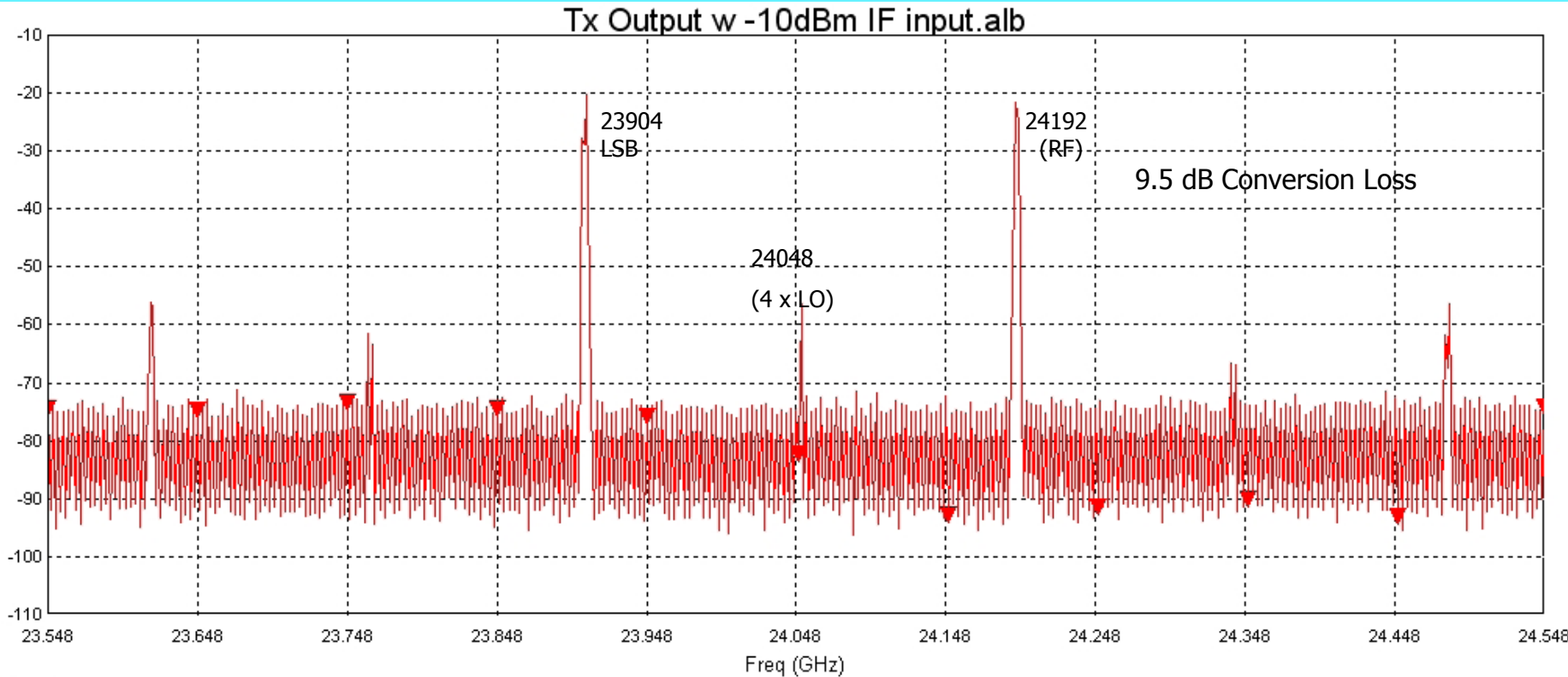

Trace0

Improvements

- Expensive Board material ! (\$\$\$\$)

Rogers 4350B Material

$\epsilon_r \sim 3.5$ (Rogers 5880 = 2.3)

- Loss tan 0.0003 @ 10 GHz (5880 = 0.0001 @ 10GHz)
- ‘Glass reinforced Hydrocarbon/Ceramic material *not* PTFE’
- Lower cost board
- Easier to process for PC board houses

New Board Design on 4350B

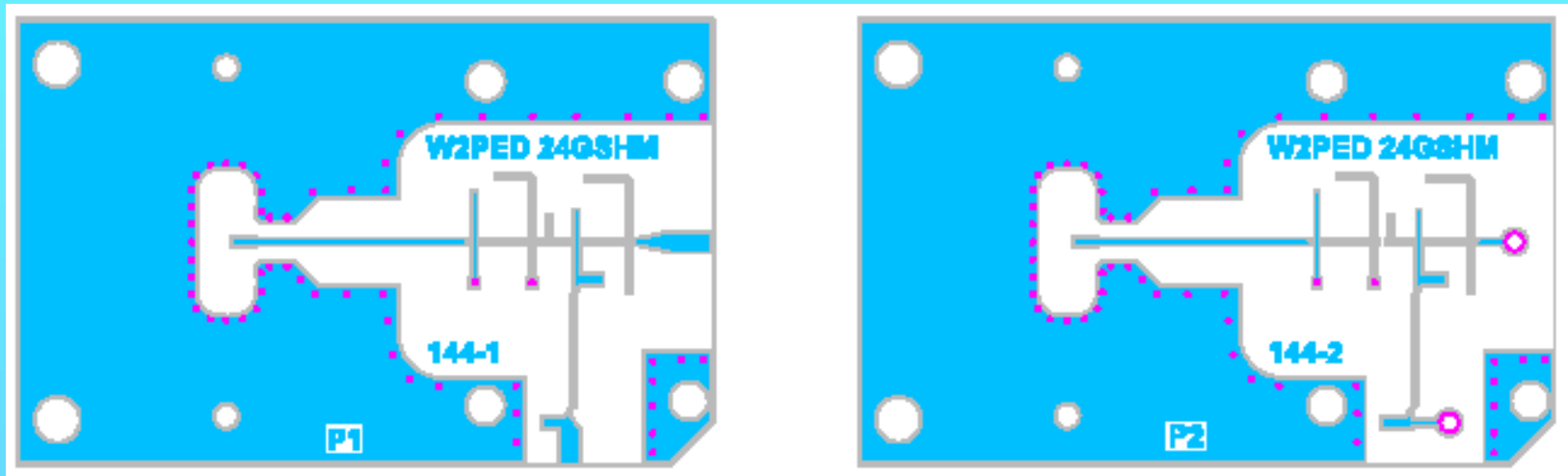

6 GHz Local Oscillator....

N5AC Synthesized LO

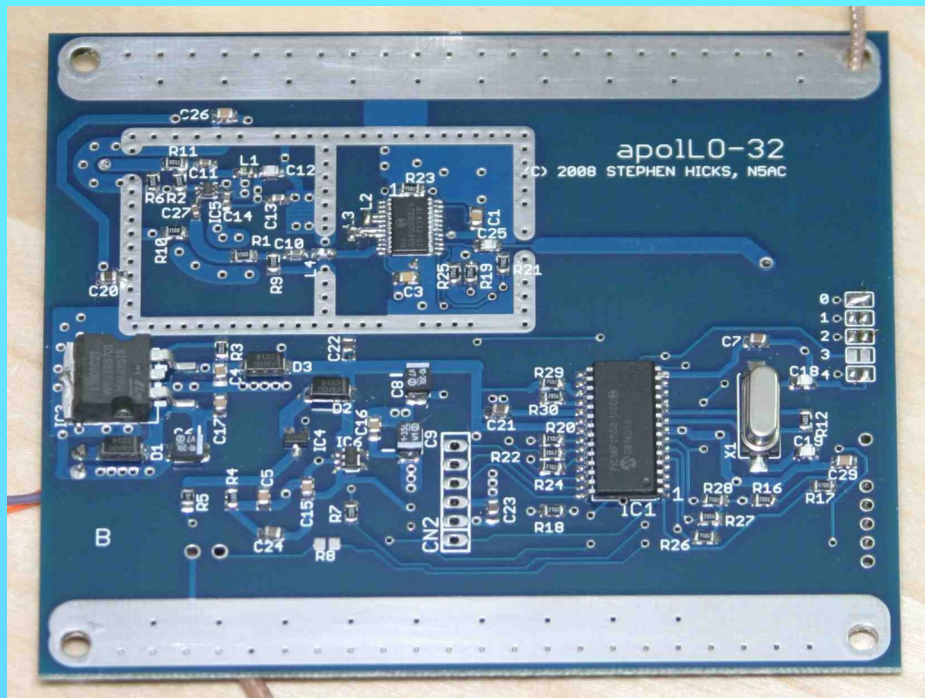

700-1300 MHz

Locked to 10 MHz (i.e. GPS)

Replacement for DEMI LO

www.n5ac.com

apolLO + W2PED Multiplier

1002 MHz

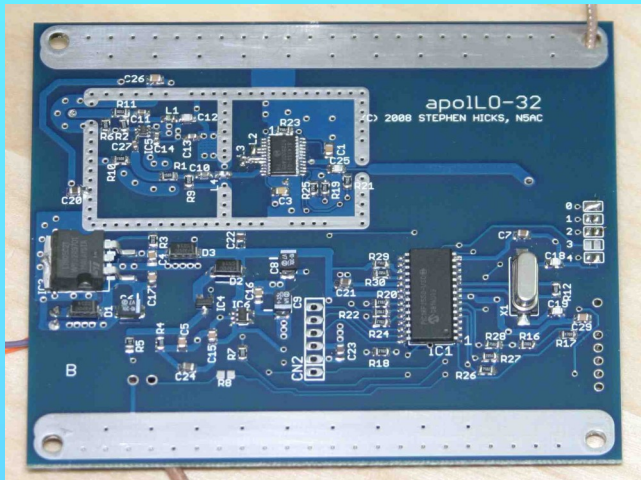

x6

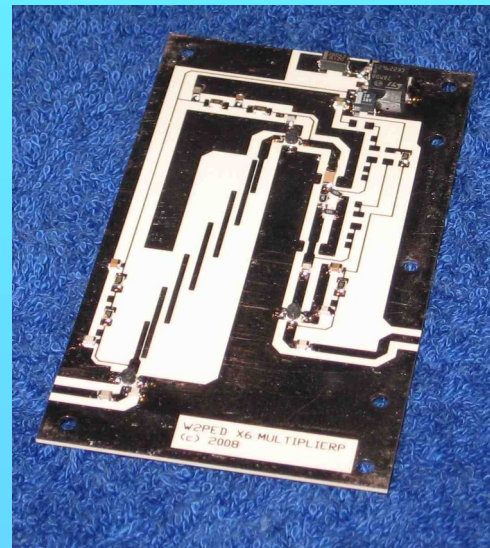

= 6012 MHz

Synthesized LO & x6 Multiplier

Components for 24 & 47GHz



Northeastern VHF Conference
w2ped April 2009

Summary

- LO is at $\frac{1}{4}$ of standard LO, or ~ 6 GHz
- Moderate LO level (+10 dBm)
- <10 dB conversion Loss
- WR42 input/output

24 GHz Transverter by K3TUF using W2PED Subharmonic

Components for 24 & 47GHz



Northeastern VHF Conference
w2ped April 2009

Components for 24 & 47GHz



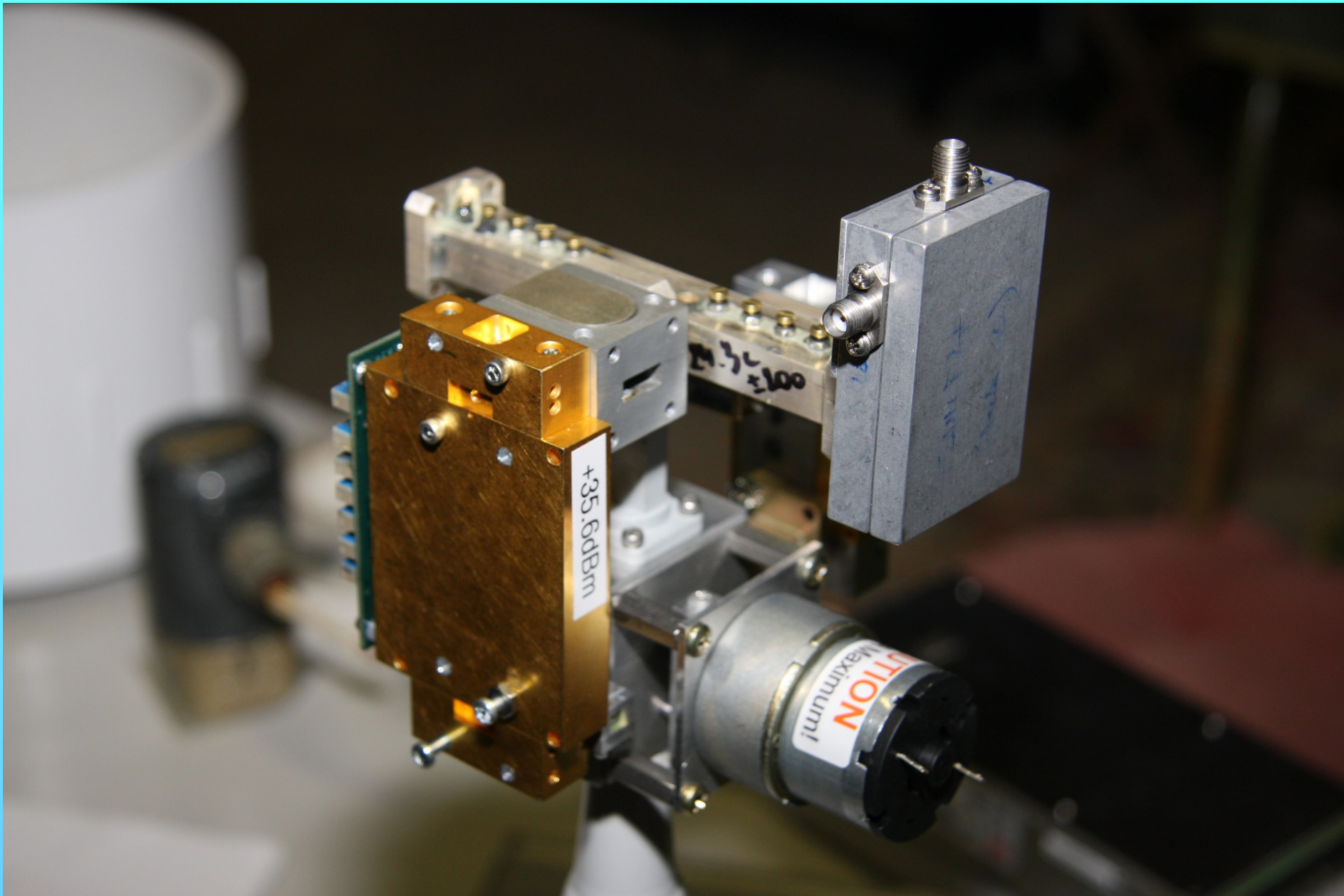

Northeastern VHF Conference
w2ped April 2009

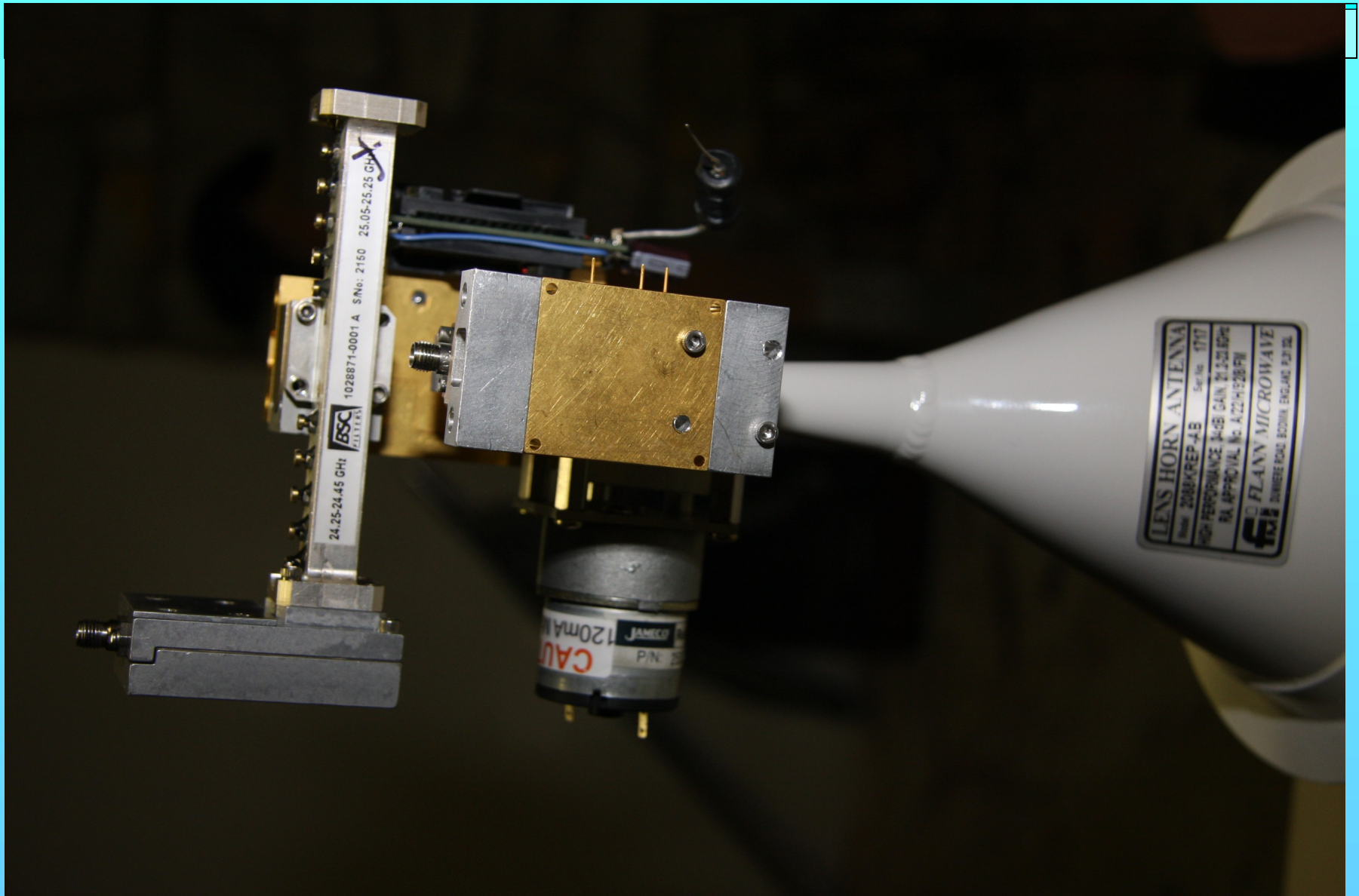

Northeastern VHF Conference
w2ped April 2009

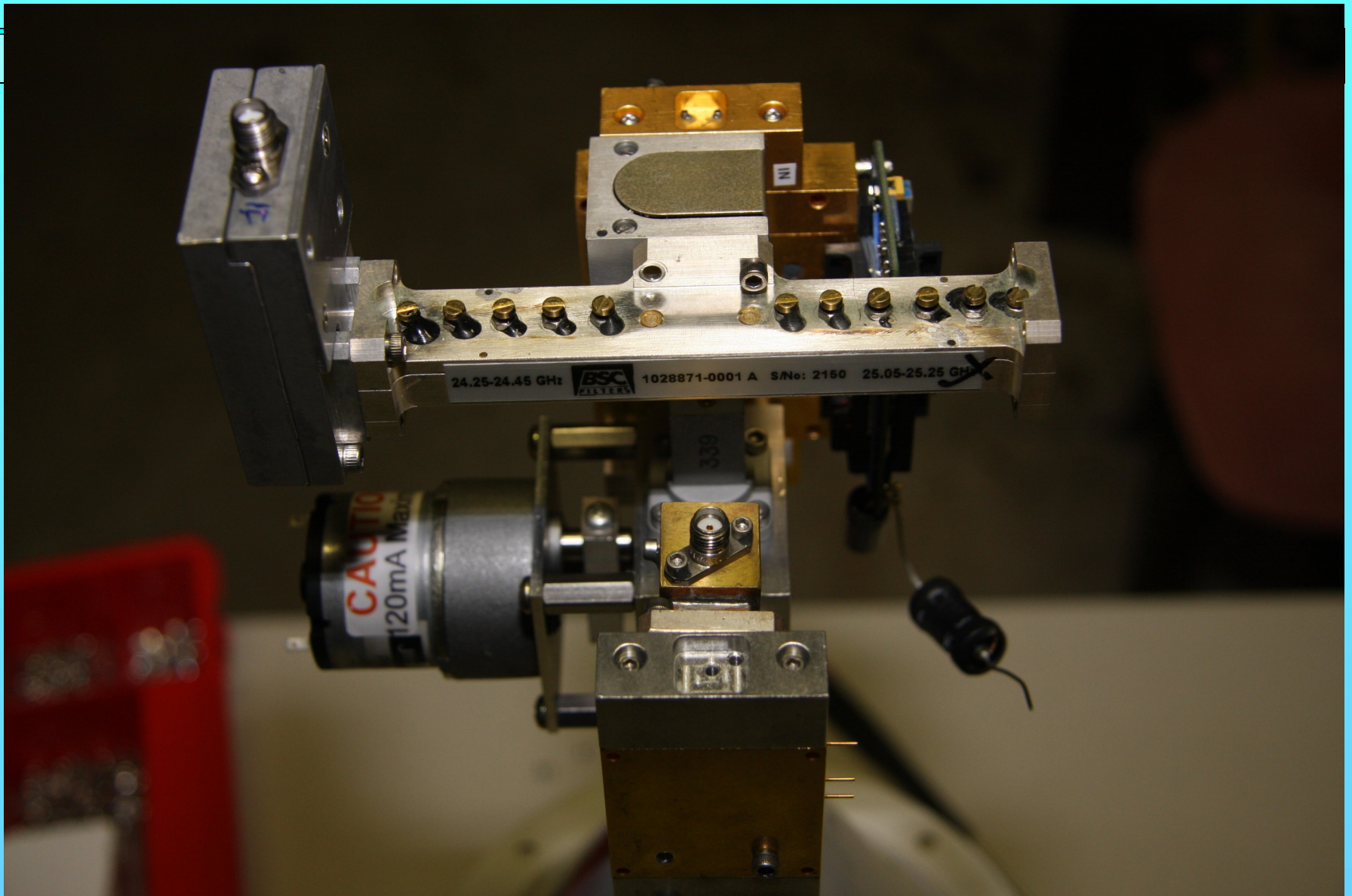

Northeastern VHF Conference
w2ped April 2009

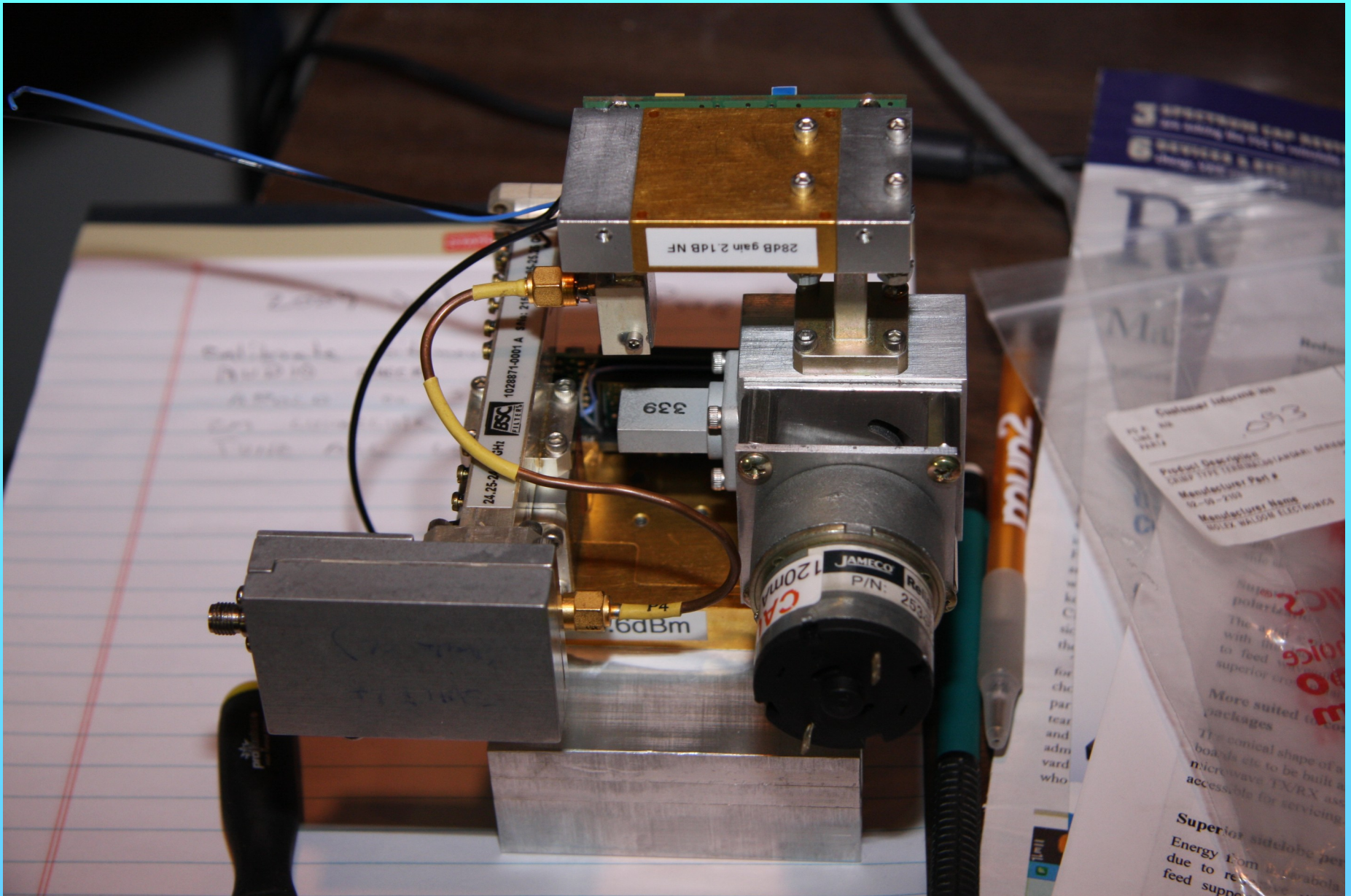

Northeastern VHF Conference
w2ped April 2009

Components for 24 & 47GHz

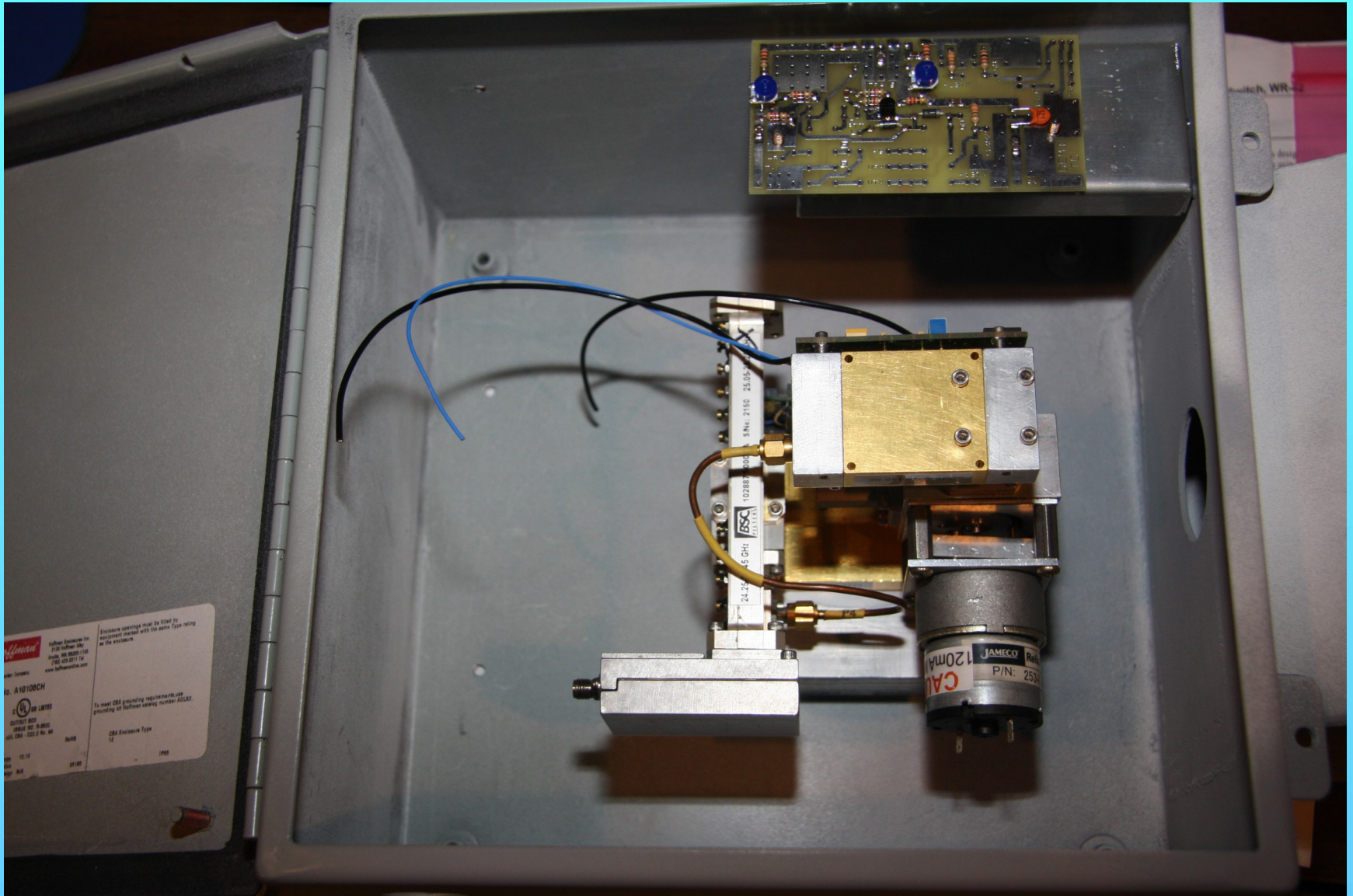



Northeastern VHF Conference
w2ped April 2009



Northeastern VHF Conference
w2ped April 2009



Northeastern VHF Conference
w2ped April 2009

Components for 24 & 47GHz



Northeastern VHF Conference
w2ped April 2009

Next Project... More Power!

